



**Power RF Amplifiers**

**Power = 10.0 Watts**

**Bandwidth = 20 to 1000 Mhz**

**Gain = 30.0 dB Vdd =28.0 Volts**

**50 ohms Input/Output Impedance**

**Description**

The MHCV01 is a 10 Watt, high gain amplifier module covering a bandwidth of 20-1000 Mhz. This compact module design is suitable for military applications in a rugged environment. An ALC pin is provided to control the output power, gain and blanking of the module.

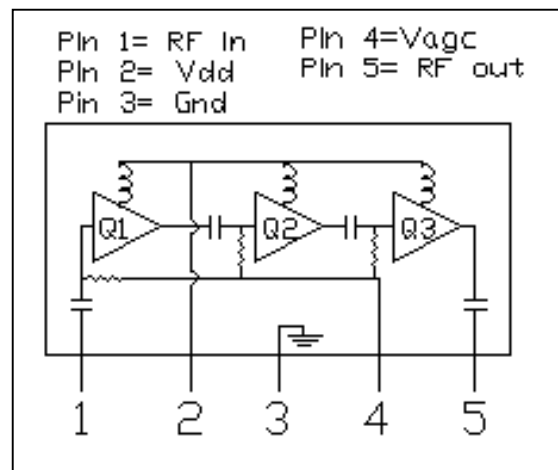
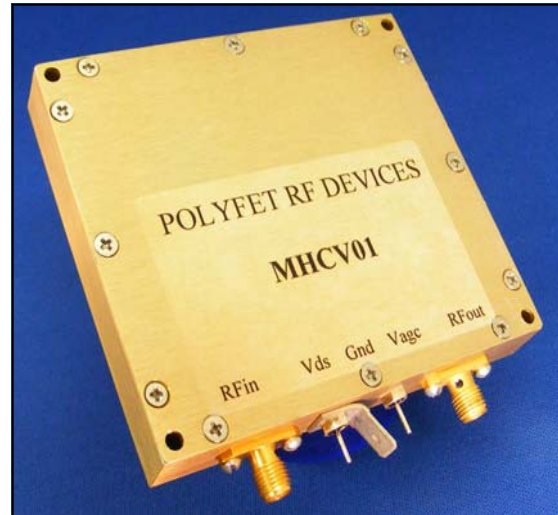

**Absolute Maximum Ratings (T=25 °C)**

Parameter	Symbol	Value	Unit
DC supply Voltage 1	VDD1	32.0	V
DC supply Voltage 2	VDD2		V
AGC Voltage	VAGC	10.0	V
AGC Current	VAGCI	1.00	mA
Input Power	Pin	0.050	W
Output Power	Pout	25.0	W
Operating Case Temp.	Tc	-40 to +85	°C
Storage Temperature	Tstg	-45 to +100	°C

**Electrical Characteristics: ( T=25 °C Zs=Zl=50 ohms, Vdd = 28.0 Volts, Idq = 2.2 Amps )**

Parameter	Symbol	Min	Typical	Max	Unit	Test Conditions
Frequency Range	BW	20		1000	Mhz	50 ohm load
Output Power	Po	10.0			Watts	Pin = 10.0 dbm Vagc = 8.0 V
Power Gain	PG	30.0			dB	Pout = 10.0 Watts Vagc = 8.0 V
Total Efficiency	$\eta$		15		%	Pout = 10.0 Watts
2nd Harmonics	ds0		-30.00		dBc	Pout = 10.0 Watts @ Mhz
Intermod - 2 tone	Im3	-25.00			dBc	AvePwr= 5.0 Watts
Load Mismatch Tolerance	VSWR	10:1			Relative	All Phase Angles
Vagc Voltage	VAGC			8.0	V	Pin = 10.0 dBm, Pout =10.0 W
Pulse Response Time	Pr			100.0	uS	Pulse source: Vagc

# MHCV01

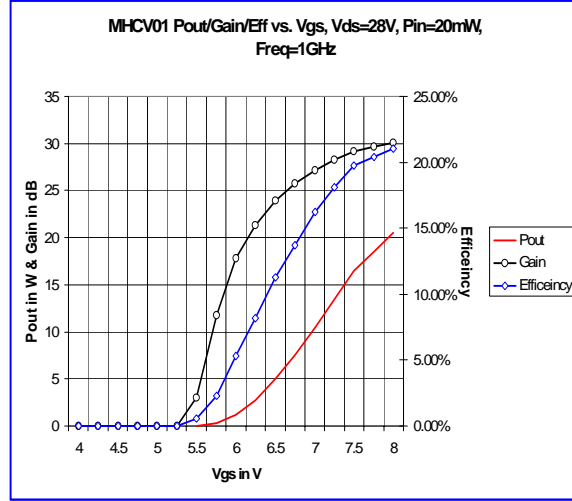
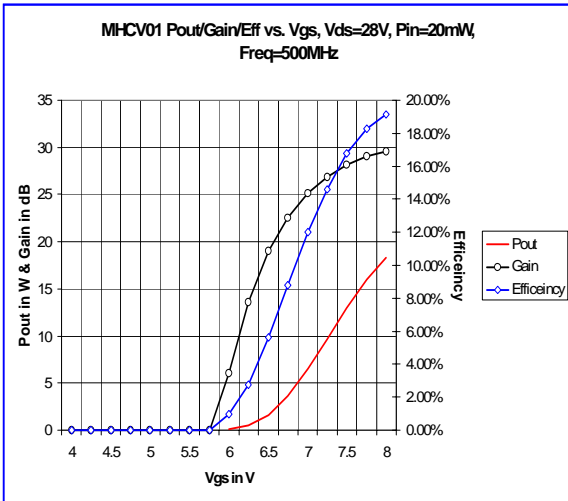
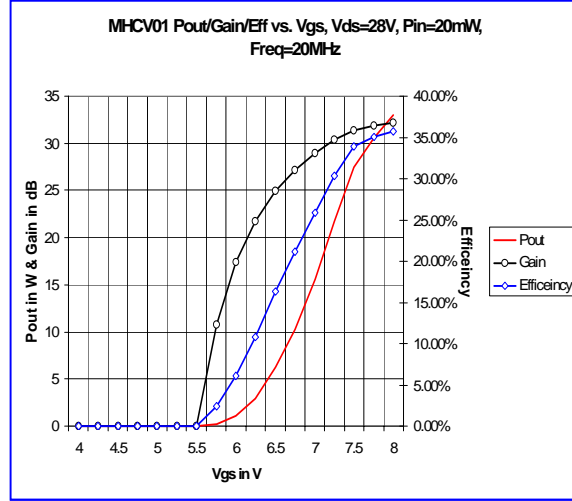
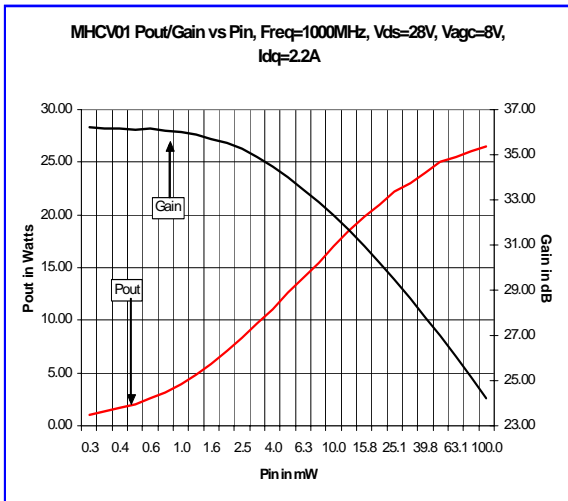
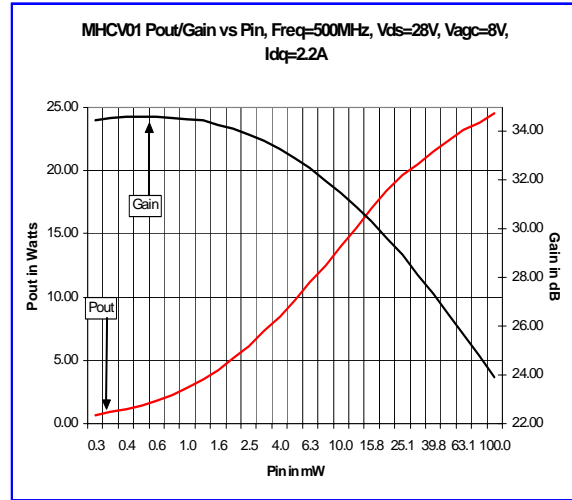
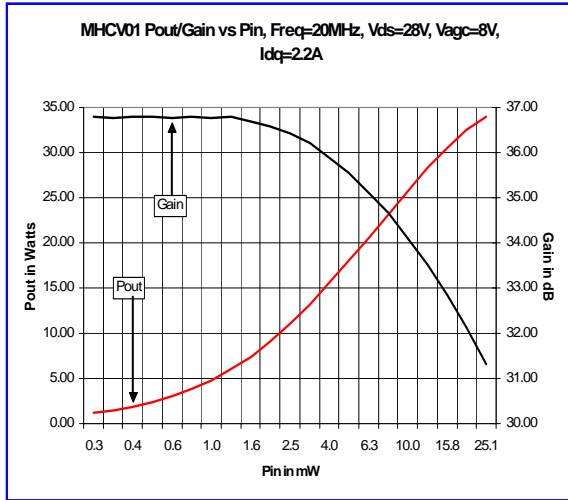

# MHCV01

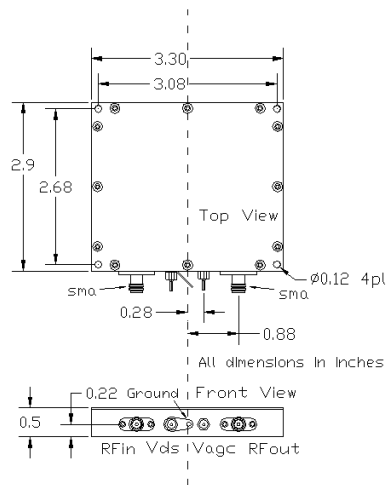
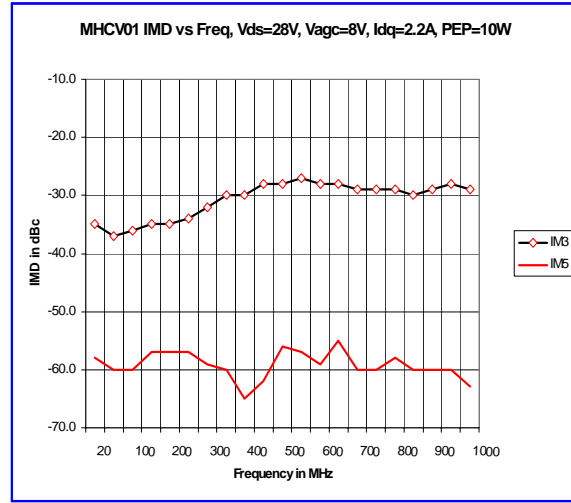
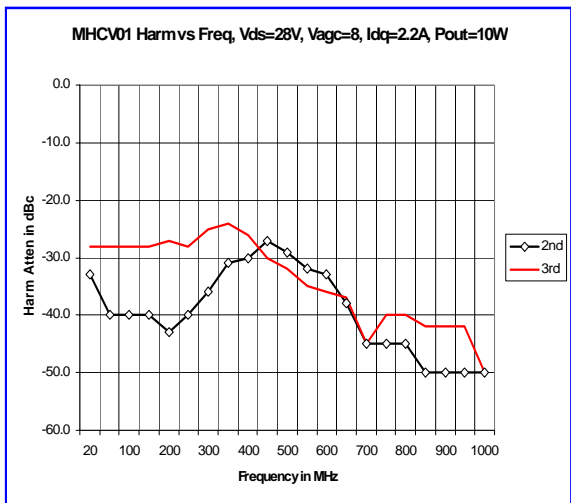
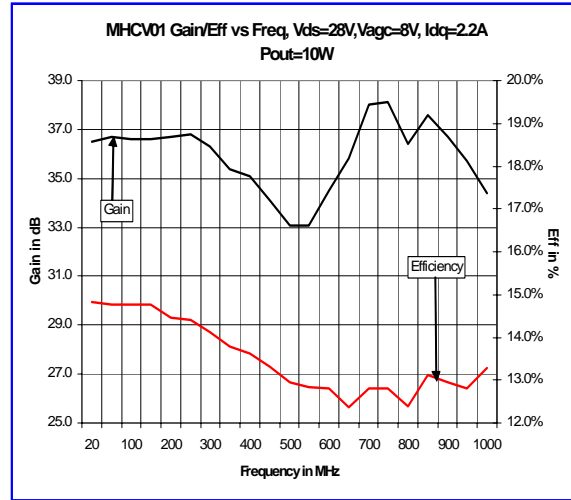
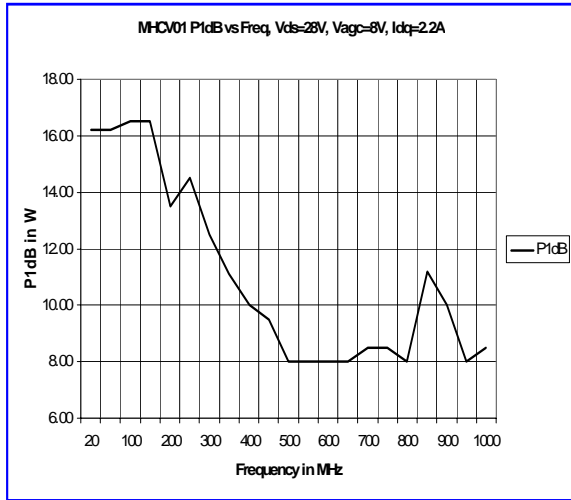

POLYFET RF DEVICES

REVISION 02/11/2009

1110 Avenida Acaso, Camarillo, Ca 93012 Tel:(805) 484-4210 FAX: (805) 484-3393 URL:www.polyfet.com